







## C15 Technical Data Sheet



### OEM Key features

-  **Reliable construction**
-  **Robust and compact design**
-  **No turbo-lag (Instant boost)**
-  **Installation flexibility**
-  **Reduced emission**
-  **Cost efficient solution**
-  **Power range: 60-175kW (82 - 238 hp)**

### GENERAL DESCRIPTION

The Rotrex C15 is an extremely compact centrifugal supercharger. Rotrex C15 is a range of centrifugal superchargers for large variety of applications where the compactness is one of the key issues. Countless number of small applications can now be boosted by this very efficient and silent unit which supplies air flow up to 0.22 kg/s.

Through the patented hi-speed planetary traction drive, the C15 achieves impeller speeds of up to 201,500 rpm. The exceptional high speeds of the drive give an unsurpassed power to size ratio compared to any other supercharger on the market.

The very low noise and vibration characteristic as well as the high efficiency of these superchargers set the industry standard for what is achievable.

The C15 range of superchargers is designed for four stroke gasoline engines. However, two stroke engines or even diesel engines can benefit from these superchargers with remarkable results. Depending on the application the C15 will support engine outputs up to 175kW. The C15 can also supply clean pressurized air for other applications such as exhaust gas after-treatment systems, agriculture applications, fuel cell power plants etc.

The groundbreaking compact size enables a very flexible supercharger installation particularly on engine applications where optimum efficiency as well as weight and size are essential. The supercharger features an integrated dual-action oil pump that works as a dry sump scavenging pump in addition to being the oil supply pump. The self-contained oil system allows flexible positioning of the supercharger on the vehicle and has the benefit of fitting the supercharger without worrying about tampering with the oil system of the engine or any other accessory.

The Rotrex C-type supercharger has been developed and extensively tested with the special Rotrex traction fluid. To maintain the ultimate level of performance and durability it is very important that the unit is exclusively run with special Rotrex traction fluid. Make sure the inlet oil temperature is within the range specified in the table on the next page. Any deviation from the standard Rotrex oil circuit requires approval from Rotrex.

## C15 range specifications

Characteristic	Symbol	C15-16	C15-20	C15-60
Power range <sup>[1]</sup>	P <sub>range</sub>	60-125kW (82-170hp)	50-120kW (68-163hp)	90-175kW (122-238hp)
Max mass flow rate	M <sub>flow</sub>	0.15 kg/s	0.15 kg/s	0.22 kg/s
Max pressure ratio (P <sub>out</sub> /P <sub>in</sub> )	PR <sub>max</sub>	2.43	2.94	2.35
Drive ratio	N	1:12.67		
Max drive efficiency	η <sub>max</sub>	97%		
Rotational direction	R <sub>in</sub> direction	Clockwise rotation, as seen from pulley side		
Pulley type	-	Fitted with pulley adapter		
Pulley ring diameters available	Ø <sub>pulley</sub>	70, 75, 80, 85, 90mm 8 rib aluminium - PK profile		
Unit weight	M	2.9 Kg (6.4 lbs)		
Peak input shaft speed	R <sub>in</sub> max	15,900 rpm	14,207 rpm	11,840 rpm
Peak impeller speed	R <sub>out</sub> max	201,500 rpm	180,000 rpm	150,000 rpm
Mass moment of inertia	I <sub>supercharger</sub>	1.251·10 <sup>-3</sup> kg·m <sup>2</sup>	1.660·10 <sup>-3</sup> kg·m <sup>2</sup>	2.057·10 <sup>-3</sup> kg·m <sup>2</sup>
Min inlet oil temperature	Toil,in <sub>min</sub>	-40°C (-40°F)		
Max inlet oil temperature	Toil,in <sub>max</sub>	+80°C (176°F)		
Mounting torque Pulley ring bolts	M6x10	10Nm (7.4 ft-lb)		
Mounting torque Bracket bolts	M5x60	4.5Nm (3.3 ft-lb)		
Mounting torque Oil banjo bolts	M10x1	21Nm (15.5 ft-lb)		

<sup>1</sup> Power output is dependent on engine type, cooling, cam-timing etc.

### Conversion Toolbox

Temperature conversion	$^{\circ}\text{C} = \frac{5}{9} \times (^{\circ}\text{F} - 32)$ OR $^{\circ}\text{F} = \frac{9}{5} \times ^{\circ}\text{C} + 32$		
Kg/s to CFM conversion	$\text{CFM} = \frac{\text{kg}}{\text{s}} \times 1731.8$	$\frac{\text{kg}}{\text{s}} = \frac{\text{CFM}}{1731.8}$	@15°C and 0.1013 MPa
Kg/s to lb/min conversion	$\frac{\text{kg}}{\text{s}} = 0.0075 \frac{\text{lb}}{\text{min}}$	$\frac{\text{lb}}{\text{min}} = \frac{\text{Kg}}{\text{s}} \times 0.0075$	

### C15-16 Compressor map

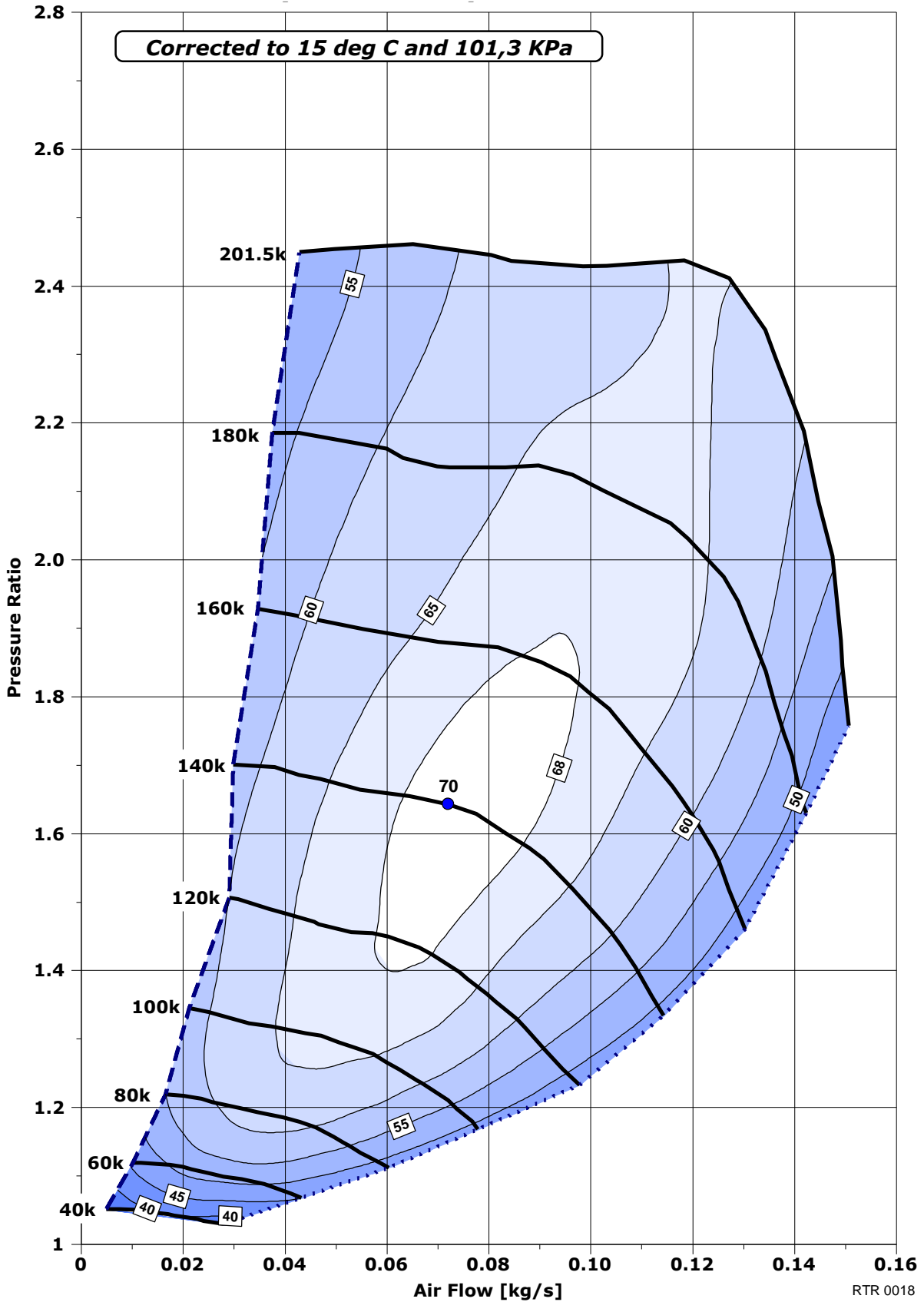

C15-20 Compressor map

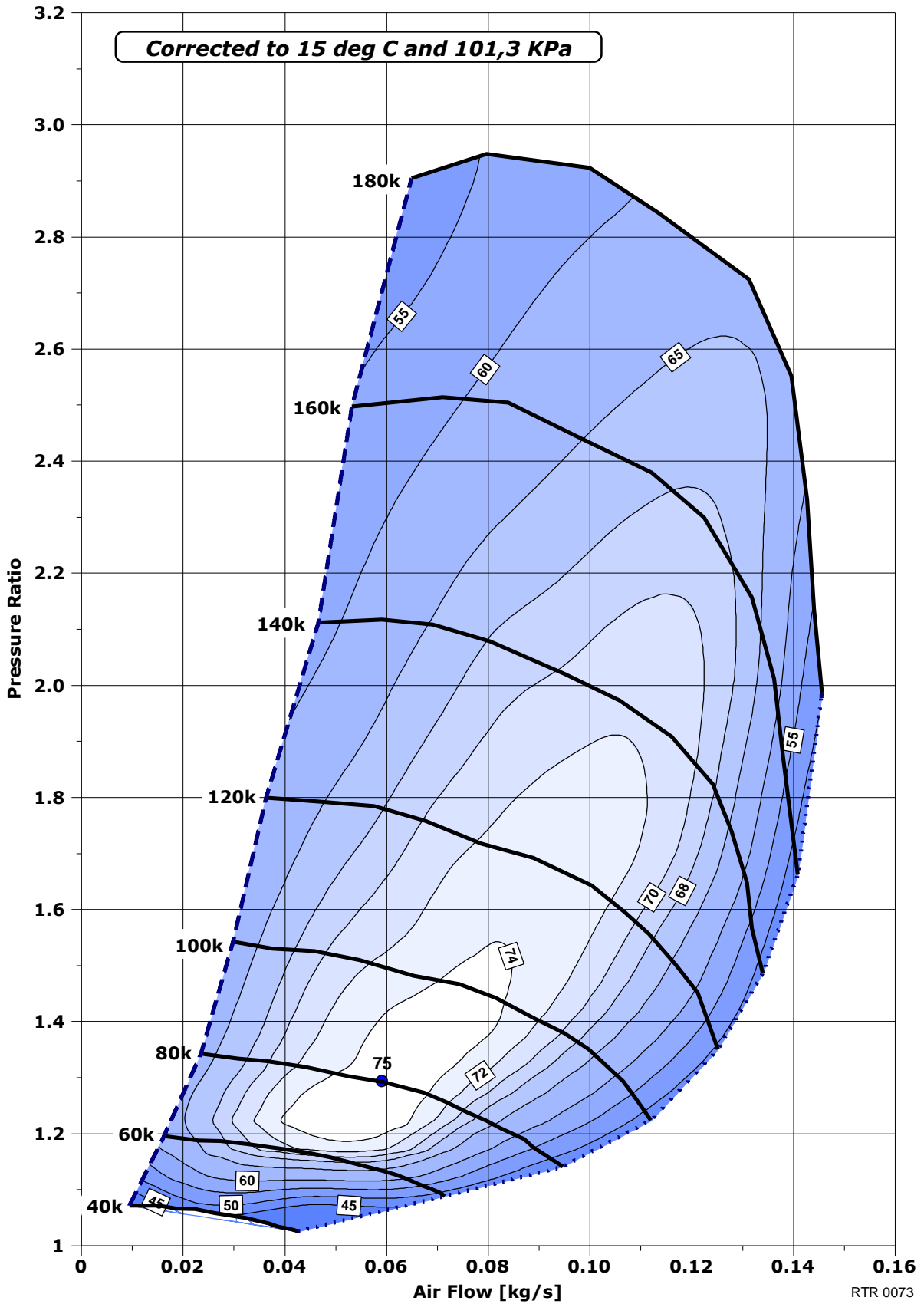

C15-60 Compressor map

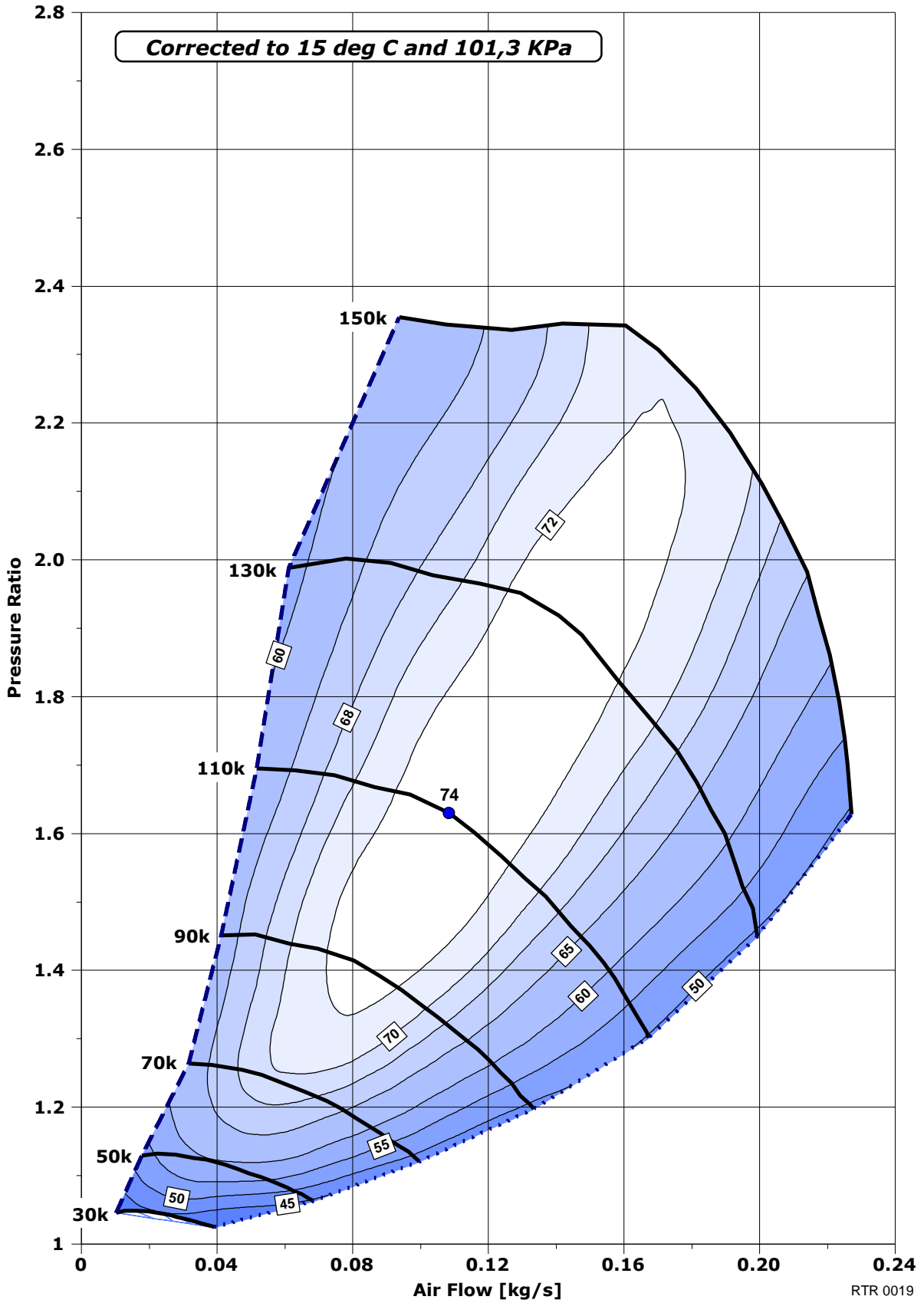

C15 range Dimensions

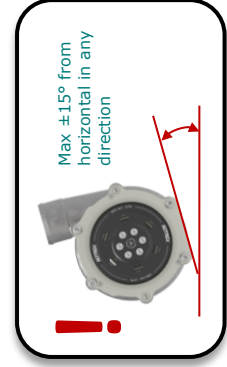

The supercharger can be ordered with the compressor housing mounted in one of six different outlet positions with 60° intervals to allow easy adoption to any application. 0° outlet direction being the Rotrex default

Possible outlet directions

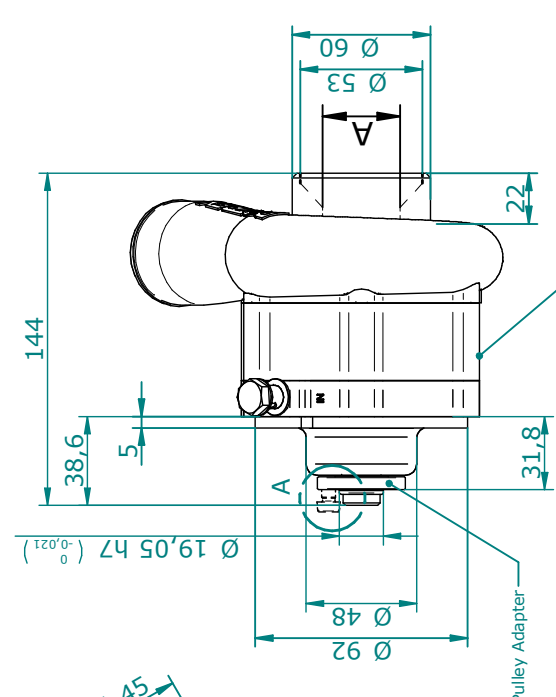
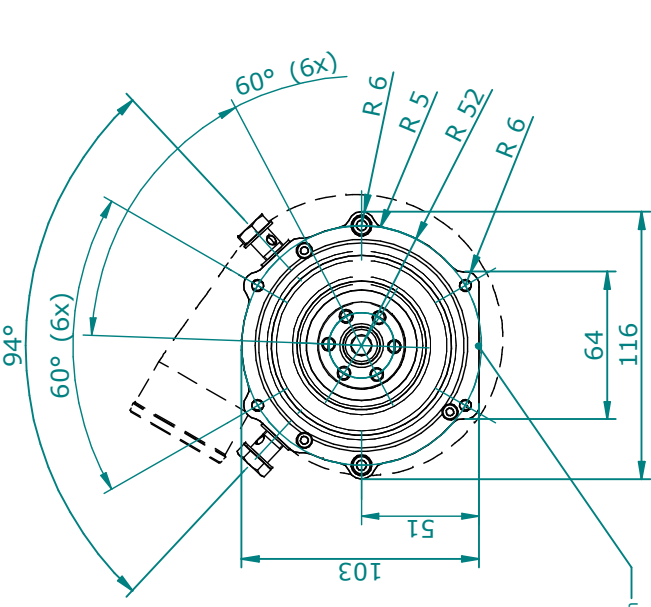
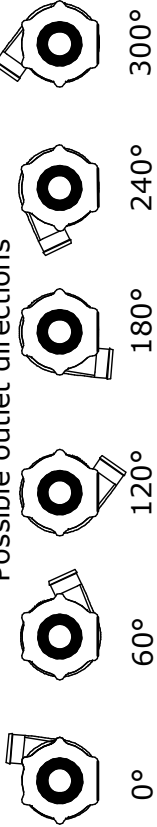

The supercharger must be positioned with the flat part facing down and within 15° from horizontal in any direction

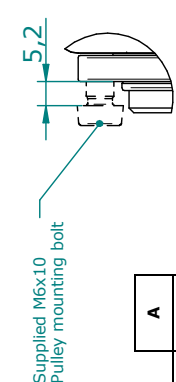

A	
C15-16	33,6
C15-20	33,6
C15-60	42,6

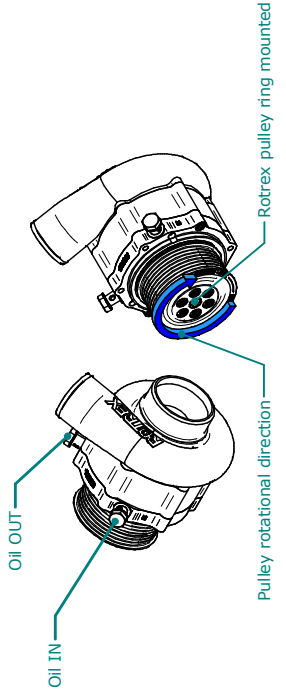

Rotrex Pulley ring Ø	70	75	80	85	90
----------------------	----	----	----	----	----

