







C30 Technical Data Sheet



OEM Key features

-  **Reliable construction**
-  **Robust and compact design**
-  **No turbo-lag (Instant boost)**
-  **Installation flexibility**
-  **Reduced emission**
-  **Cost efficient solution**
-  **Power range: 120-320kW (163 - 435 hp)**

GENERAL DESCRIPTION

The C30 is a range of centrifugal superchargers with a very versatile application range. Countless number of medium size applications can be boosted by this very efficient and silent unit which supplies air flow up to 0.39 kg/s.

Impeller speeds of up to 120,000 rpm are achieved through the patented hi-speed planetary traction drive which combines small size with exceptional performance and durability.

The very low noise and vibration characteristic as well as the high efficiency of these superchargers set the industry standard for what is achievable.

The C30 range of superchargers is designed for four stroke gasoline engines. However, two stroke engines or even diesel engines can benefit from these superchargers with remarkable results. Depending on the application the C30 will support engine outputs up to 320kW. Where one supercharger is not enough, it is possible to use two units to support large amounts of power in a twin-charger configuration. The C30 can also supply clean pressurized air for other applications such as industrial systems, exhaust gas after-treatment systems, agriculture applications, fuel cell power plants etc.

The groundbreaking compact size enables a very flexible supercharger installation particularly on engine applications with tight space and where weight and size are essential.

The supercharger features an integrated dual-action oil pump that works as a dry sump scavenging pump in addition to being the oil supply pump. The self-contained oil system allows flexible positioning of the supercharger on the vehicle and has the benefit of fitting the supercharger without worrying about tampering with the oil system of the engine or any other accessory.

The Rotrex C-type supercharger has been developed and extensively tested with the special Rotrex traction fluid. To maintain the ultimate level of performance and durability it is very important that the unit is exclusively run with special Rotrex traction fluid. Make sure the inlet oil temperature is within the range specified in the table on the next page. Any deviation from the standard Rotrex oil circuit requires approval from Rotrex.

C30 range specifications

Characteristic	Symbol	C30-64	C30-74	C30-84	C30-94	C30-94 CCW
Rotational direction	R _{direction}	Clockwise rotation, as seen from pulley side				CCW ^[1]
Power range ^[2]	P _{range}	120-235kW (163-320hp)	135-255kW (184-347hp)	140-265kW (190-360hp)	145-320kW (197-435hp)	
Max mass flow rate	M _{flow}	0.28 kg/s	0.31 kg/s	0.32 kg/s	0.39 kg/s	
Max pressure ratio (P _{out} /P _{in})	PR _{max}	2.68	2.82	2.82	2.52	
Mass moment of inertia	I _{Supercharger}	5.08·10 ⁻³ kg·m ²	5.14·10 ⁻³ kg·m ²	5.14·10 ⁻³ kg·m ²	5.153·10 ⁻³ kg·m ²	
Drive ratio	N	1:9.49				
Max drive efficiency	η _{max}	97%				
Unit weight	M	5.1 Kg (11.2 lbs)				
Pulley type	-	Fitted with pulley adapter				
Rotrex Pulley ring diameters available	∅ _{pulley}	70, 75, 80, 85, 90, 95, 100, 105, 110 mm 8 rib aluminium - PK profile				
Peak input shaft speed	R _{inmax}	12,600 rpm			10,500 rpm	
Peak impeller speed	R _{outmax}	120,000 rpm			100,000 rpm	
Min inlet oil temperature	Toil,in _{min}	-40°C (-40°F)				
Max inlet oil temperature	Toil,in _{max}	+80°C (176°F)				
Mounting torque Pulley ring bolts	M6x10	10Nm (7.4 ft-lb)				
Mounting torque Bracket bolts	M6x78	9Nm (6.6 ft-lb)				
Mounting torque Oil banjo bolts	M10x1	21Nm (15.5 ft-lb)				

[1] (CCW) Counterclockwise rotation, as seen from pulley side

[2] Power output is dependent on engine type, cooling, cam-timing etc.

Conversion Toolbox	
Temperature conversion	$^{\circ}\text{C} = \frac{5}{9} \times (^{\circ}\text{F} - 32)$ OR $^{\circ}\text{F} = \frac{9}{5} \times ^{\circ}\text{C} + 32$
Kg/s to CFM conversion	$\text{CFM} = \frac{\text{kg}}{\text{s}} \times 1731.8$ $\frac{\text{kg}}{\text{s}} = \frac{\text{CFM}}{1731.8}$ @15°C and 0.1013 MPa
Kg/s to lb/min conversion	$\frac{\text{kg}}{\text{s}} = 0.0075 \frac{\text{lb}}{\text{min}}$ $\frac{\text{lb}}{\text{min}} = \frac{\text{Kg}}{0.0075}$

C30-64 Compressor map

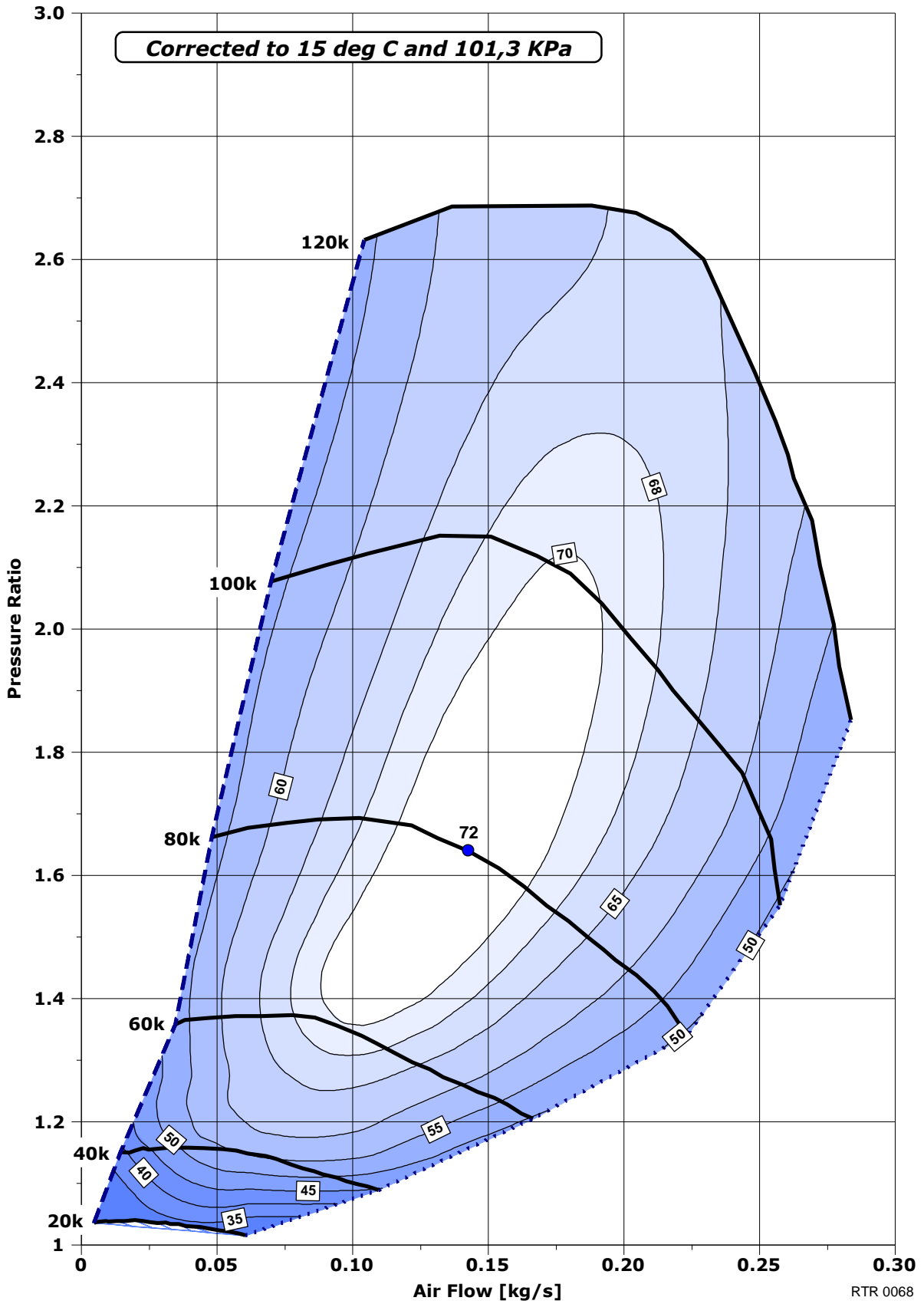

C30-74 Compressor map

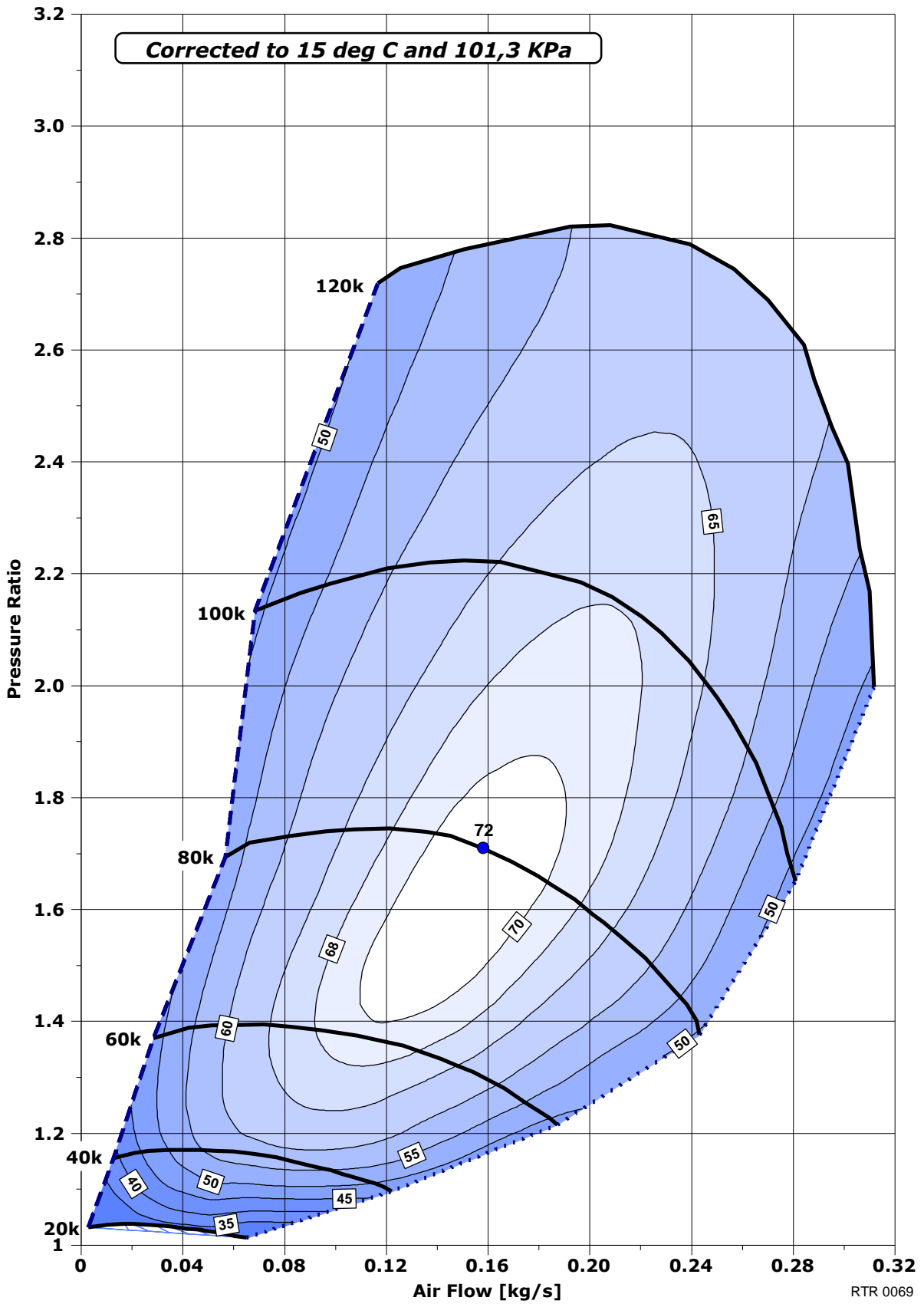

C30-84 Compressor map

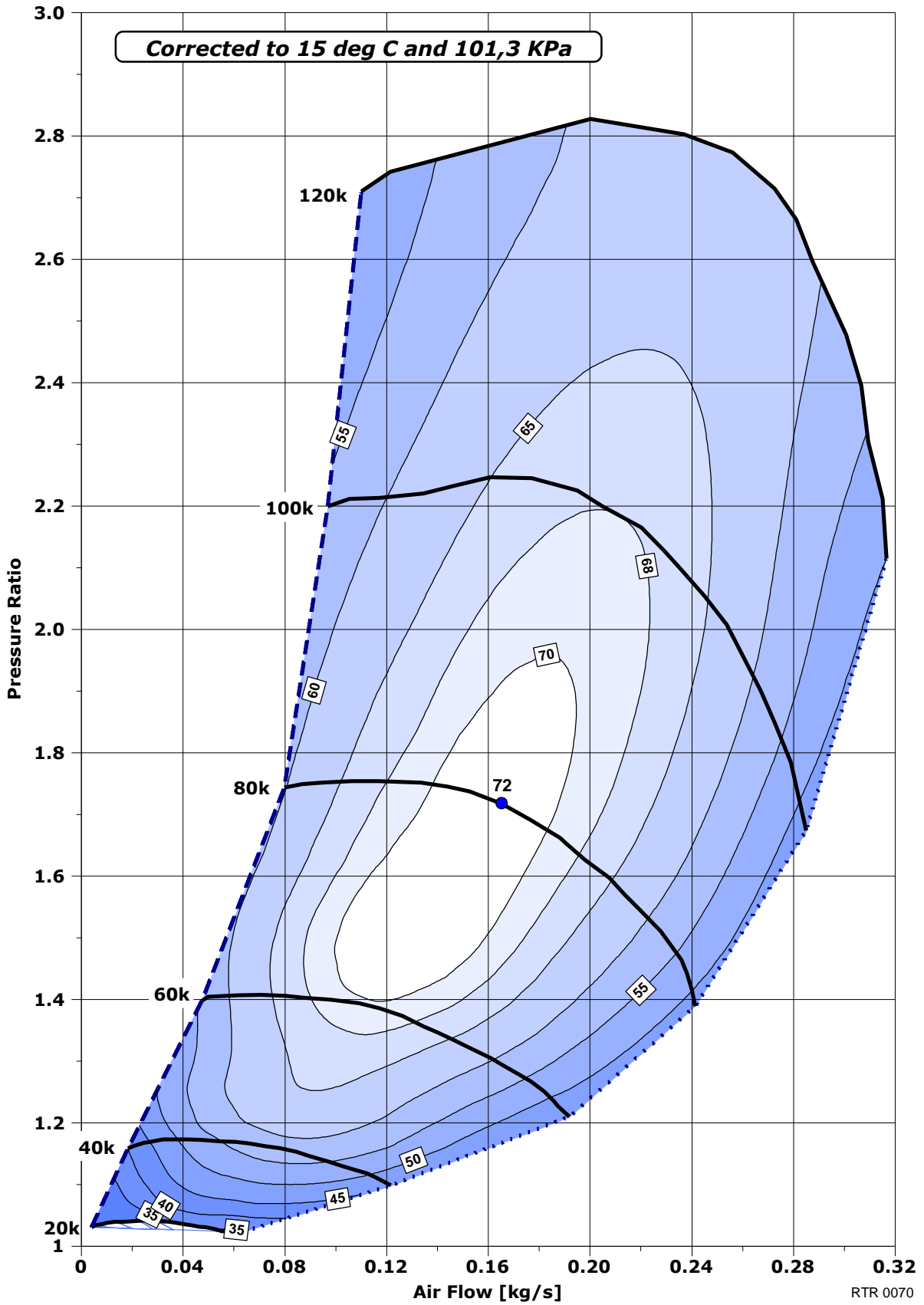

C30-94/C30-94 CCW Compressor map

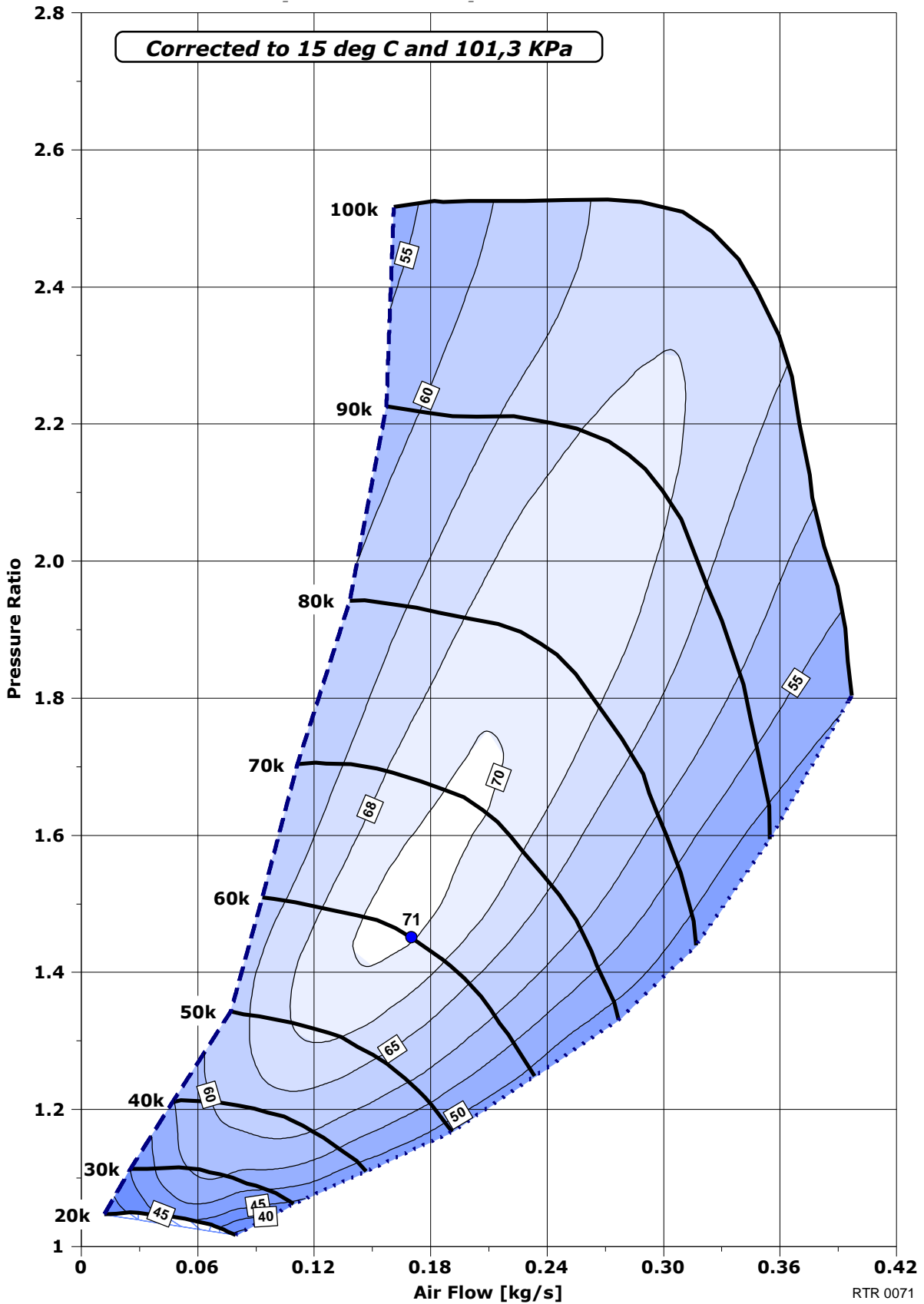

C30 range Dimensions

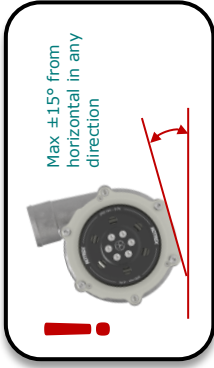

The supercharger can be ordered with the compressor housing mounted in one of six different outlet positions with 60° intervals to allow easy adoption to any application. 0° outlet direction being the Rotrex default

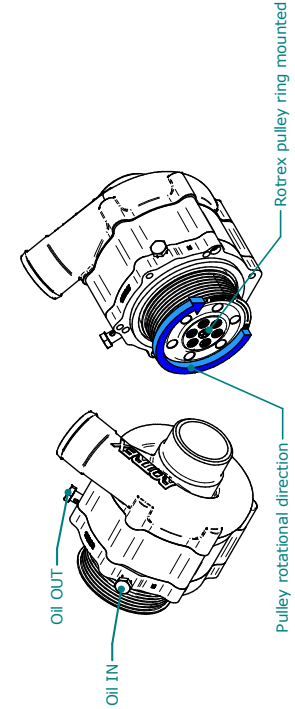
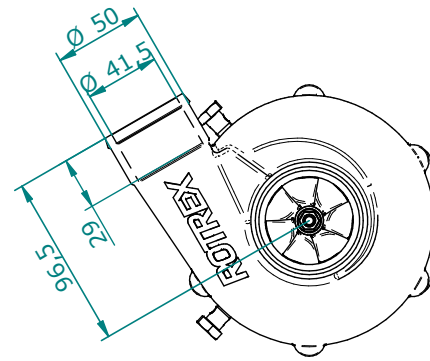
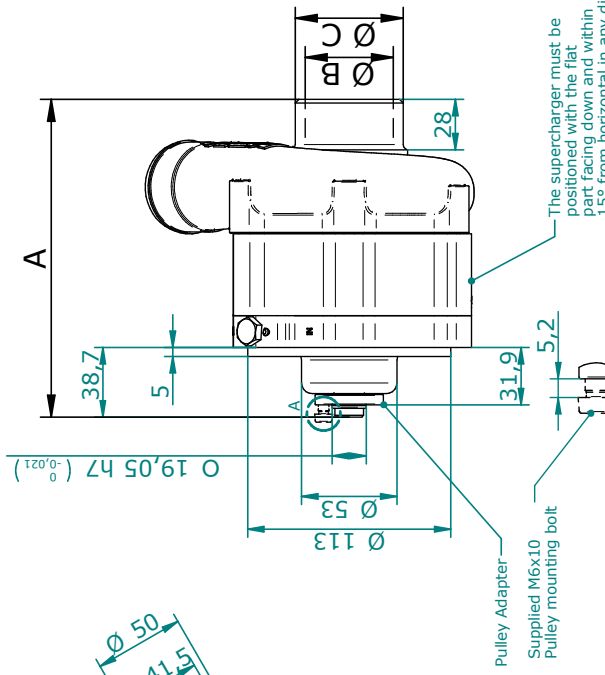
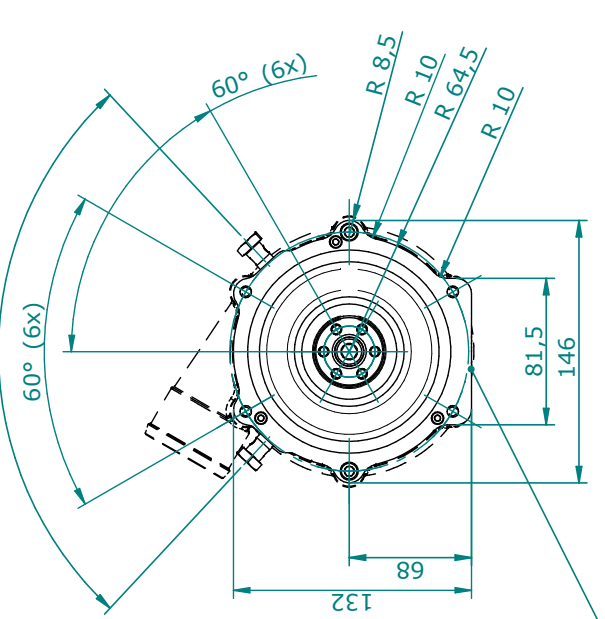
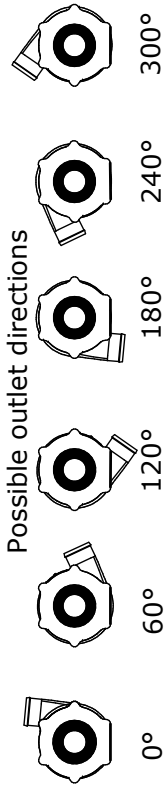

DETAIL A

	A	B	C
C30-64	178	49	60
C30-74	178	51	60
C30-84	182	51	76
C30-94	182	61	76

All dimensions in mm unless otherwise specified

Rotrex Pulley ring ø	70	75	80	85	90	95	100	105	110
----------------------	----	----	----	----	----	----	-----	-----	-----



C30-94 CCW Dimensions



The supercharger can be ordered with the compressor housing mounted in one of six different outlet positions with 60° intervals to allow easy adoption to any application. 0° outlet direction being the Rotrex default

Possible outlet directions

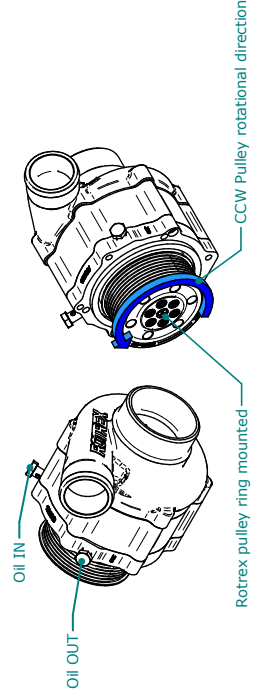
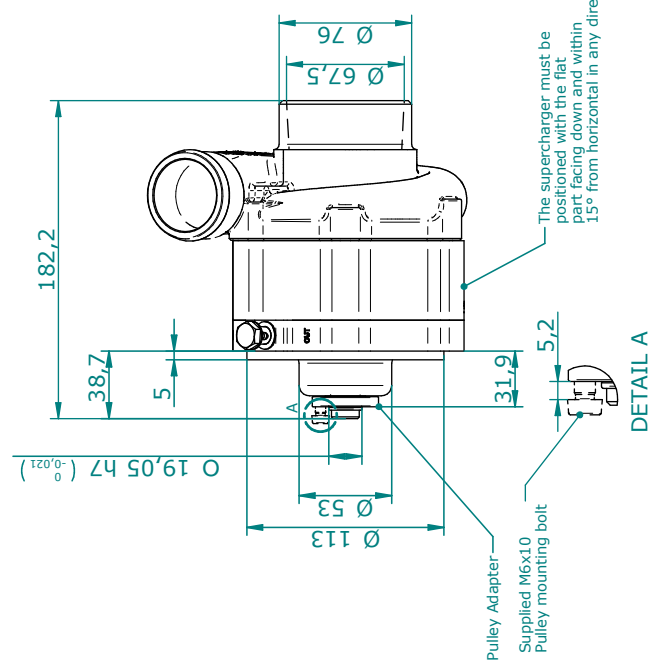
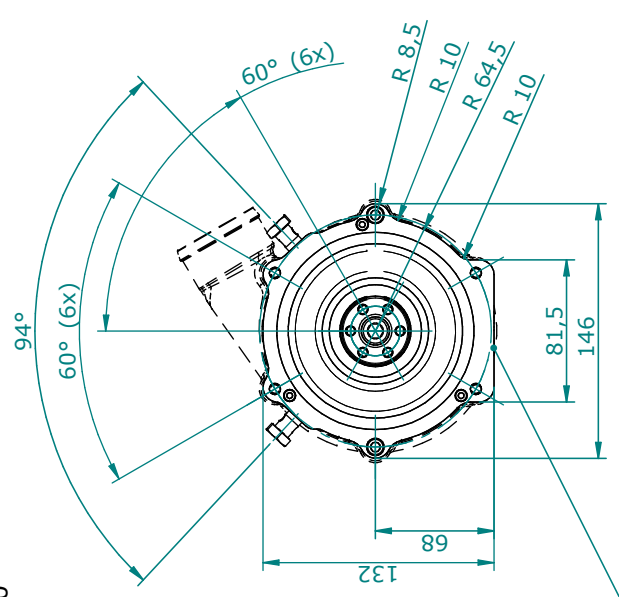
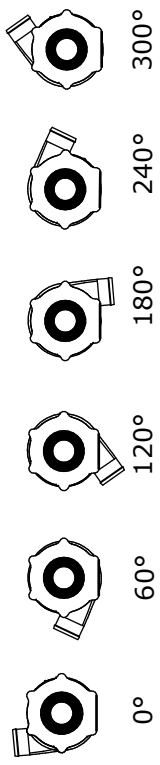

All dimensions in mm unless otherwise specified

Rotrex Pulley ring Ø	70	75	80	85	90	95	100	105	110
----------------------	----	----	----	----	----	----	-----	-----	-----

